



**The Name for
Attenuators**

CONTINUOUSLY VARIABLE ATTENUATORS 1 – 18 GHz CA Series with Turns Counting Dial

Alan Industries' CA Series of Continuously Variable Attenuators with a Turns Counting Dial enables quick and accurate adjustment of the attenuation level between various settings. The Turns Counting Dial features a locking lever to hold attenuation settings for an extended period. Units are available in either surface mount or panel mount configurations.

- SMA Connectors
- Turns Counting Dial with Locking Lever
- Surface Mount or Panel Mount
- 50 Ohm nominal impedance
- Average power 5 Watts
- -65° C to +125° C range

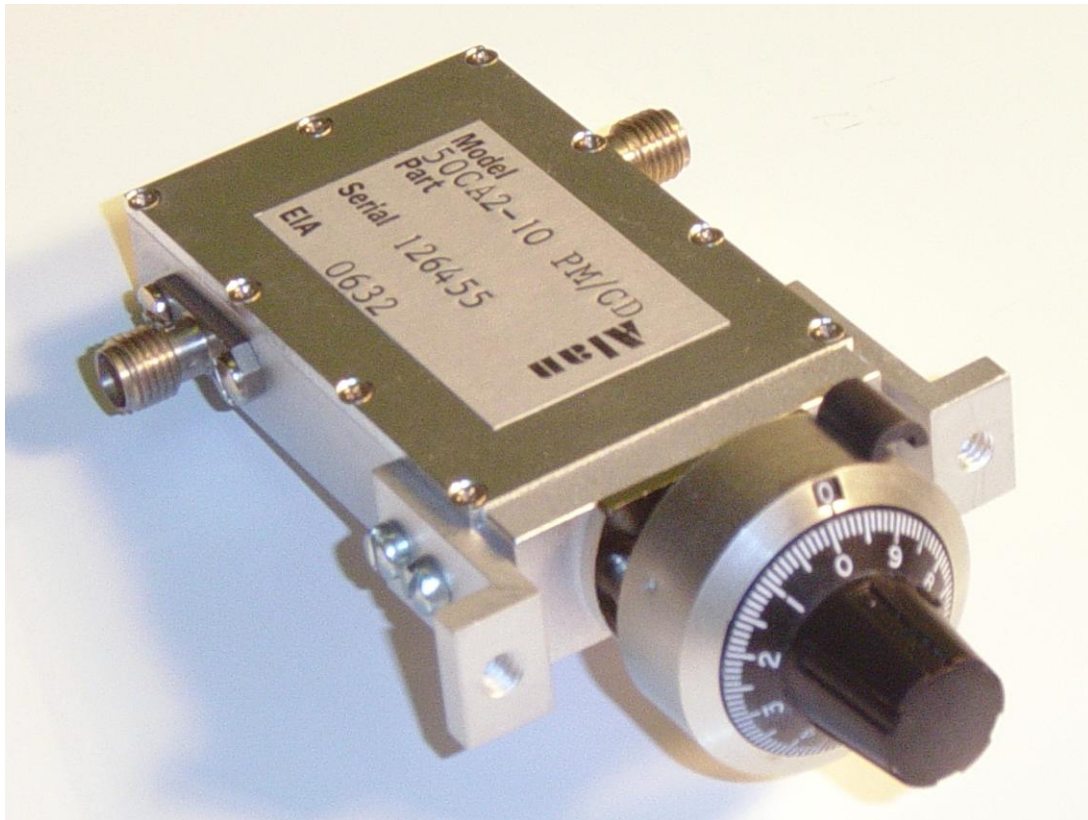

Alan

Industries, Inc.

745 Greenway Drive • Columbus, Indiana 47201 • USA
800-423-5190 or 812-372-8869 • Fax: 812-372-5909
www.alanindustries.com • sales@alanindustries.com



**The Name for
Attenuators**

CA Series with Turns Counting Dial

ELECTRICAL SPECIFICATIONS

MODEL	FREQUENCY RANGE	ATTENUATION RANGE	SWR MAX.	INSERTION LOSS MAX	PHYSICAL SIZE
50CA2-10	1 - 2 GHz	7 dB	2.0:1	0.5 dB	Type 2
50CA4-10	2 - 4 GHz	10 dB	1.8:1	0.5 dB	Type 1
50CA4-20		20 dB	1.5:1		Type 2
50CA4-40		40 dB	1.6:1		Type 3
50CA8-10	4 - 8 GHz	10 dB	1.5:1	0.75 dB	Type 1
50CA8-20		20 dB	1.5:1		Type 1
50CA8-30		30 dB	1.5:1		Type 2
50CA8-40		40 dB	1.8:1		Type 3
50CA12.4-10	8 - 12.4 GHz	10 dB	1.7:1	0.75 dB	Type 1
50CA12.4-20		20 dB			Type 1
50CA12.4-30		30 dB			Type 1
50CA12.4-40		40 dB			Type 1
50CA18-10	12.4 - 18 GHz	10 dB	1.5:1	0.75 dB	Type 1
50CA18-20		20 dB			Type 1
50CA18-30		30 dB			Type 1
50CA18-40		40 dB			Type 1
RoHS COMPLIANCE		RoHS Compliant upon request			

TO ORDER SPECIFY: Model number as appears above. Add SM/CD for surface mount or PM/CD for panel mount.

Alan

Industries, Inc.

745 Greenway Drive • Columbus, Indiana 47201 • USA
800-423-5190 or 812-372-8869 • Fax: 812-372-5909
www.alanindustries.com • sales@alanindustries.com



The Name for
Attenuators

CA Series with Turns Counting Dial

SM/CD PHYSICAL DIMENSIONS

PHYSICAL SIZE	Dim. A	Dim. B	Dim. C	Dim. D	Dim. E
Type 1	1.750	1.000	0.250	0.750	1.875
Type 2	2.100	1.350	0.425	0.925	2.125
Type 3	3.450	2.750	0.425	2.275	2.125

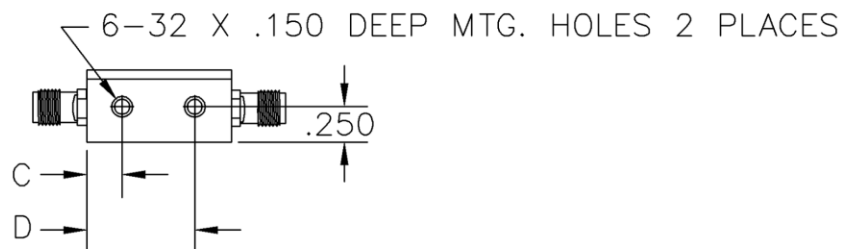
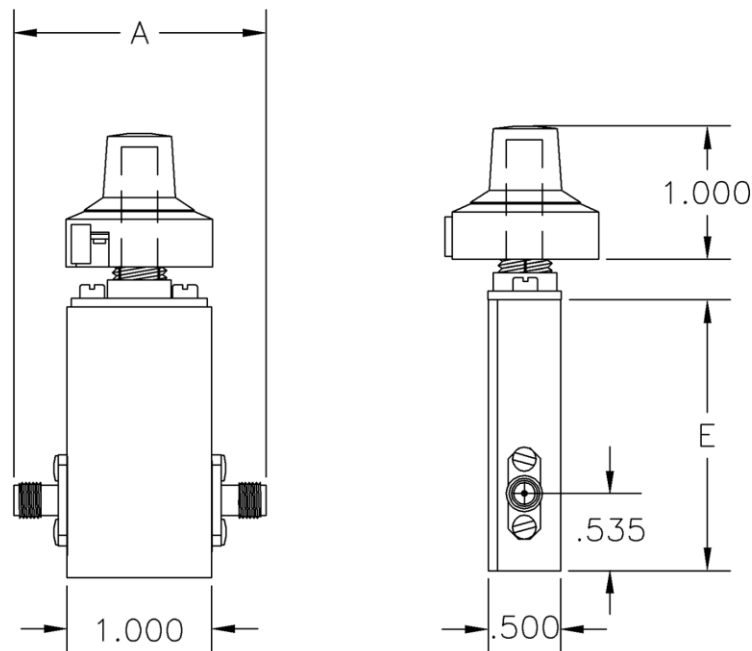

Alan

Industries, Inc.

745 Greenway Drive • Columbus, Indiana 47201 • USA
800-423-5190 or 812-372-8869 • Fax: 812-372-5909
www.alanindustries.com • sales@alanindustries.com



**The Name for
Attenuators**

CA Series with Turns Counting Dial

PM/CD PHYSICAL DIMENSIONS

PHYSICAL SIZE	Dim. A	Dim. B	Dim. C	Dim. D	Dim. E
Type 1	1.750	1.000	2.255	1.600	1.320
Type 2	2.100	1.350	2.505	1.950	1.670
Type 3	3.450	2.700	2.505	3.300	3.020

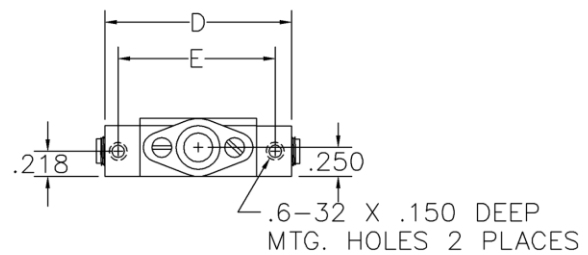
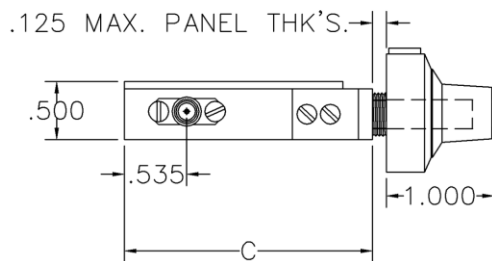
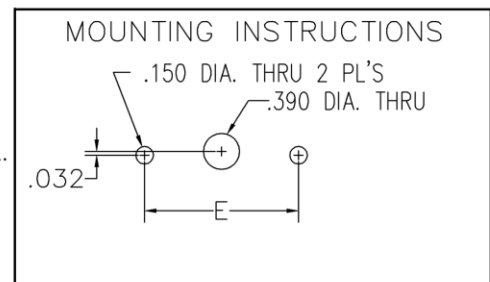
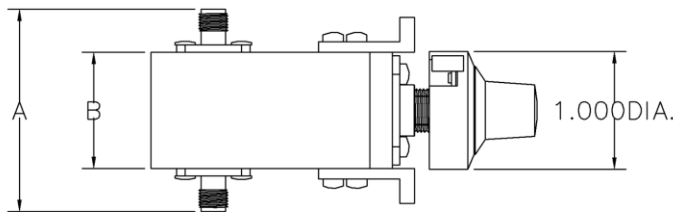

DIAL SHOWN REMOVED FOR CLARITY

Alan

Industries, Inc.

745 Greenway Drive • Columbus, Indiana 47201 • USA
800-423-5190 or 812-372-8869 • Fax: 812-372-5909
www.alanindustries.com • sales@alanindustries.com