



**The Name for  
Attenuators**

## **CELLULAR / PCS MINIATURE STEP ATTENUATORS PCS Series**

Alan Industries' PCS Series is a Miniature Step Attenuator with up to 60 dB of total attenuation covering the Cellular / PCS frequencies of DC - 2200 MHz. These units are supplied with index stops, knobs and provisions for panel mounting.



**Alan**

Industries, Inc.

745 Greenway Drive • Columbus, Indiana 47201 • USA  
800-423-5190 or 812-372-8869 • Fax: 812-372-5909  
www.alanindustries.com • sales@alanindustries.com



**The Name for  
Attenuators**

**PCS Series**

## **ELECTRICAL SPECIFICATIONS**

| <b>MODEL</b>           | <b>50PCS10 SMA</b>                                 | <b>50PCS60 SMA</b> |
|------------------------|--|--------------------|
| FREQUENCY RANGE        | DC – 2200 MHz                                      |                    |
| ATTENUATION RANGE      | 0 - 10 dB  | 0 - 60 dB          |
| ATTENUATION STEPS      | 1 dB   | 10 dB              |
| ACCURACY               | ± 0.4 dB   | ± 0.5 dB or 3%     |
| INSERTION LOSS MAX.    | 0.5 dB   | 1 dB               |
| MAXIMUM SWR            | 1.5:1  |                    |
| AVERAGE POWER          | 1 Watt   |                    |
| TEMPERATURE RANGE      | -20° C to +125° C                                  |                    |
| CONNECTORS             | SMA  |                    |
| MOUNTING               | Panel Mount standard<br>Bench-Top bracket optional |                    |
| <b>RoHS COMPLIANCE</b> | <b>RoHS Compliant upon request</b>                 |                    |

**TO ORDER SPECIFY:** Model numbers as appears above, add –BT for Bench-Top bracket

**Alan**

**Industries, Inc.**

**745 Greenway Drive • Columbus, Indiana 47201 • USA  
800-423-5190 or 812-372-8869 • Fax: 812-372-5909  
www.alanindustries.com • sales@alanindustries.com**



**The Name for  
Attenuators**

**PCS Series**

## PHYSICAL DIMENSIONS

| MODEL   | A     | B     |
|---------|-------|-------|
| 50PCS10 | 0.719 | 1.803 |
| 50PCS60 | 1.500 | 2.664 |

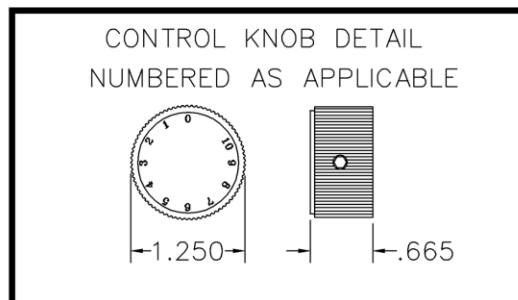
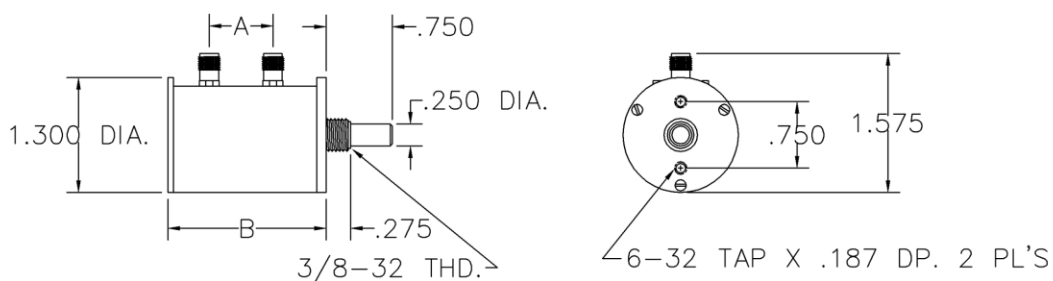

**Alan**

Industries, Inc.

745 Greenway Drive • Columbus, Indiana 47201 • USA  
800-423-5190 or 812-372-8869 • Fax: 812-372-5909  
www.alanindustries.com • sales@alanindustries.com



**The Name for  
Attenuators**

**PCS Series**

## **BENCH –TOP BRACKET OPTION**

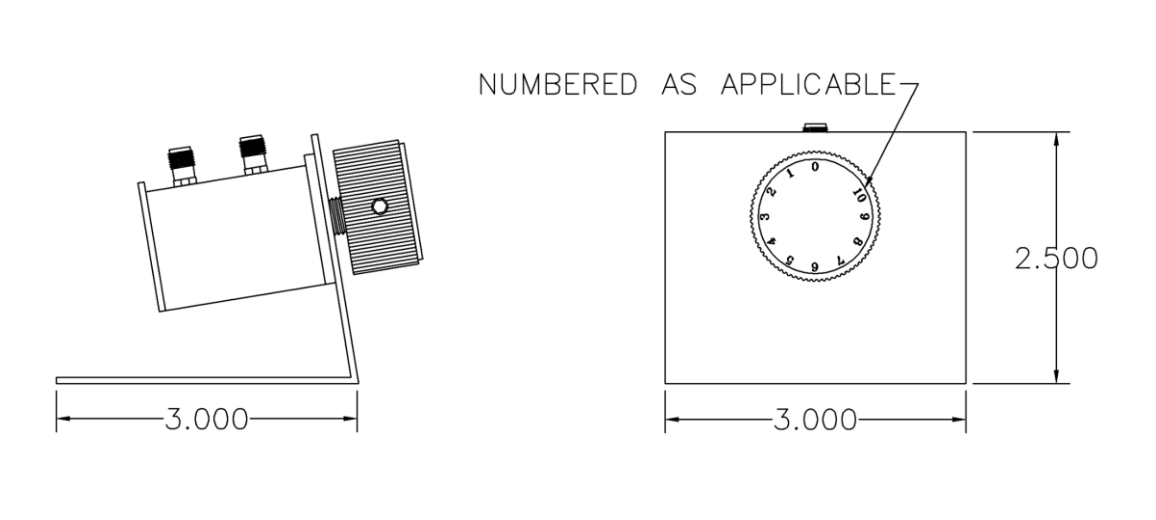

**Alan**

**Industries, Inc.**

**745 Greenway Drive • Columbus, Indiana 47201 • USA  
800-423-5190 or 812-372-8869 • Fax: 812-372-5909  
www.alanindustries.com • sales@alanindustries.com**